

# KERR

## PUMPS

### KT-3400XP

79 BHP Triplex Plunger Pump

Continuous Duty

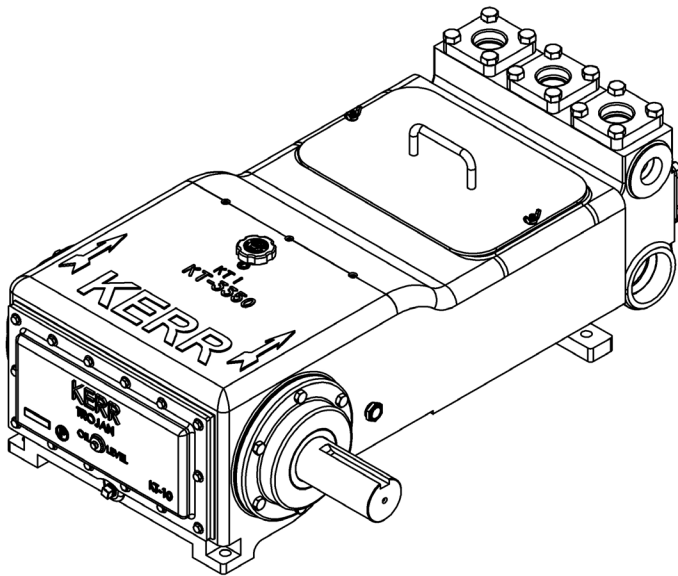

KT-3400XP RH

### SPECIFICATIONS

Configuration	Horizontal Triplex Plunger
Number of Plungers	3
Stroke Length	4" / 101.6 mm
Frame Load Rating	6,055 lbs
Fluid Cylinder Pressure Rating	3,600 PSI
Pump Weight (Avg.)	1,200 lbs / 545 kilos
Kerr Max Speed	385 RPM
API-674 Max Speed	350 RPM
Minimum Speed	100 RPM
Mechanical Efficiency (Bare Shaft)	90%
Lube System (Standard)	Splash - Gravity Feed
Lube System (Optional)	Force Feed
Lube Oil Capacity	16 quarts / 15.4 liters
Lube Oil Type	Petroleum per AGMA 5EP (ISO 220) or Synthetic per SAE 75W-90 (ISO 100)
Connection Sizes	3" NPT Suction 1 1/2" NPT Discharge

### FLUID END

Cast Ductile Iron (65-45-12)
Cast Carbon Steel (WCB)
Cast Nickel Aluminium Bronze (955)
Cast Stainless Steel CF8M (316)
Cast Duplex SS CD3MN (2205)
Forged Carbon Steel (A105)
Forged Stainless Steel (316)

### VALVES

DISC TYPE / SEAT (MAX. 2,160 PSI)	WING GUIDED
Delrin Disc / SS (316)	Ni-Al-Brz (955) / Metal-to-Metal
Delrin / Ni-Al-Brz (955)	Monel / Metal-to-Metal
Delrin / Duplex SS (CD4MCU)	SS (316) / Metal-to-Metal
SS (316) / SS (316)	17-4 HT Metal-to-Metal
Titanium / SS (316)	SS (316) / AR Urethane Inserted
PEEK / SS (316)	17-4 HT / AR Urethane Inserted

### PLUNGERS

Colmonoy 730 Hard Coat
Solid Ceramic (2,160 Max. PSI)
Kerramic (Ceramic) Coated
Solid 316 Stainless Steel

\* Consult Factory for Authorized Drawings for Dimensions

1) Displacement is based on 100% Volumetric Efficiency (VE)

2) Consult factory for operating speeds above maximum shown

3) 1 US gallon = 3.78541 liters

# KERR

## PUMPS

### KT-3400XP

79 BHP Triplex Plunger Pump

Continuous Duty

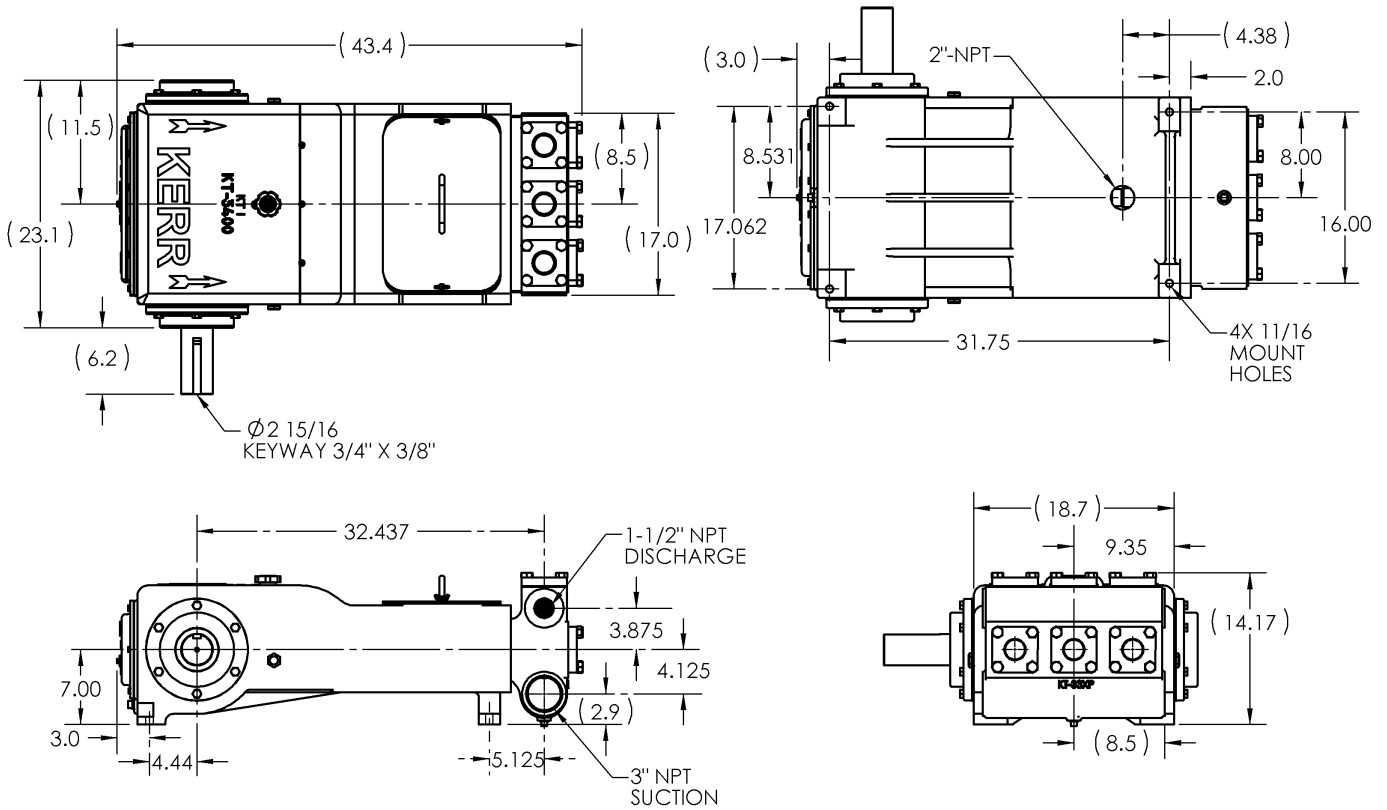
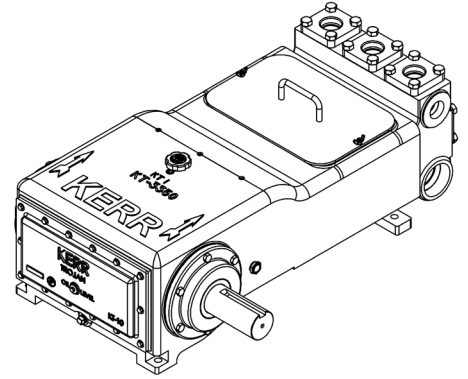

PLGR DIA. INCHES	MAX PRESS. PSI	DISP GAL PER REV	DISPLACEMENT																	
			100 RPM		150 RPM		200 RPM		250 RPM		275 RPM		310 RPM		325 RPM		350 RPM		385 RPM	
			GPM	BPD	GPM	BPD	GPM	BPD	GPM	BPD	GPM	BPD	GPM	BPD	GPM	BPD	GPM	BPD	GPM	BPD
1.500	3426	0.0918	9.2	315	13.8	472	18.4	630	22.9	787	25.2	866	28.5	976	29.8	1023	32.1	1102	35.3	1212
1.750	2517	0.1249	12.5	429	18.7	643	25.0	857	31.2	1071	34.4	1179	38.7	1329	40.6	1393	43.7	1500	48.1	1650
2.000	1927	0.1632	16.3	560	24.5	840	32.6	1120	40.8	1399	44.9	1539	50.6	1735	53.0	1819	57.1	1959	62.8	2155
2.250	1523	0.2065	20.7	708	31.0	1063	41.3	1417	51.6	1771	56.8	1948	64.0	2196	67	2303	72	2480	80	2728

\* Consult Factory for Authorized Drawings for Dimensions

1) Displacement is based on 100% Volumetric Efficiency (VE)

2) Consult factory for operating speeds above maximum shown

3) 1 US gallon = 3.78541 liters